

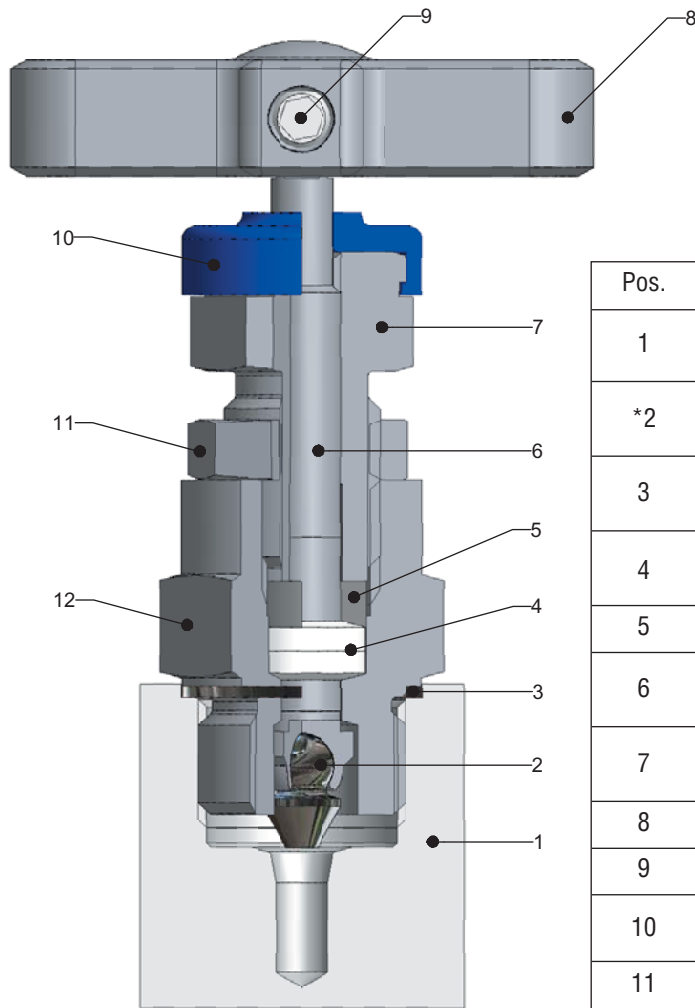

# Werkstoff-Datenblatt

Bul 4190 MS  
Juni 2002

Max. Betriebsdruck 6000 psig (414 barg)  
Hochdruckbereich 10000 psig (689 barg)  
PTFE-Packung: Max. 260 °C (500 °F)  
Grafoil-Packung: Max. 538 °C (537,78 °C)



Pos.	Beschreibung	Werkstoff							
		Edelstahl	Monel	Duplex	Hastelloy	Titan	6Mo	Incoloy	Inconel
1	Körper	Edelst. 316 ASTM A479	Monel M400	Duplex UNS 31803	Hastelloy C-276	Titan GR-2	6Mo	Incoloy 825	Inconel 625
*2	Spindel- spitze	Edelst. 17-4PH	Monel K500	Duplex UNS S.32750/32760	Hastelloy B2	Titan GR-5	Duplex UNS S.32750/32760	Inconel 625	Inconel 718
3	Dichtungs- ring	Edelst. 316 ASTM A479	Monel M400	Duplex UNS 31803	Hastelloy C-276	Titan GR-2	6Mo	Incoloy 825	Inconel 625
4	Packung	PTFE / Grafoil	PTFE / Grafoil	PTFE / Grafoil	PTFE / Grafoil	PTFE / Grafoil	PTFE / Grafoil	PTFE / Grafoil	PTFE / Grafoil
5	Druckbuchse	Edelst. 316	Edelst. 316	Edelst. 316	Edelst. 316	Edelst. 316	Edelst. 316	Edelst. 316	Edelst. 316
6	Spindel	Edelst. 316 ASTM A479	Monel M400	Duplex UNS 31803	Hastelloy C-276	Titan GR-2	6Mo	Incoloy 825	Inconel 625
7	Einstell- buchse	Edelst. 316 ASTM A479	Edelst. 316 ASTM A479	Edelst. 316 ASTM A479	Edelst. 316 ASTM A479	Edelst. 316 ASTM A479	Edelst. 316 ASTM A479	Edelst. 316 ASTM A479	Edelst. 316 ASTM A479
8	Griff	Edelst. 316	Edelst. 316	Edelst. 316	Edelst. 316	Edelst. 316	Edelst. 316	Edelst. 316	Edelst. 316
9	Gewindestift	Edelst. A4-80	Edelst. A4-80	Edelst. A4-80	Edelst. A4-80	Edelst. A4-80	Edelst. A4-80	Edelst. A4-80	Edelst. A4-80
10	Staubkappe	LDPE - Farbig	LDPE - Farbig	LDPE - Farbig	LDPE - Farbig	LDPE - Farbig	LDPE - Farbig	LDPE - Farbig	LDPE - Farbig
11	Gegenmutter	Edelst. 316	Edelst. 316	Edelst. 316	Edelst. 316	Edelst. 316	Edelst. 316	Edelst. 316	Edelst. 316
12	Ventilhals	Edelst. 316 ASTM A479	Monel M400	Duplex UNS 31803	Hastelloy C-276	Titan GR-2	6Mo	Incoloy 825	Inconel 625

\*Weiche Spitzen aus PEEK und PCTFE für Gasanwendungen erhältlich

Besuchen Sie uns im Internet: [www.parker.com/ipd](http://www.parker.com/ipd)

## Monoflansch - Maßtabelle

Größe	Klasse	Außen-Ø +0,6 / -0,0	T +0,5 / -0,0	Anz. der Bohr.	Bohrungs-Ø +0,5 / -0,0	P.C.D. +0,3 / -0,3	t +0,3 / -0,3	R +0,3 / -0,3	L +0,5 / -0,0	B +0,5 / -0,0
1/2" N.B.	150 LB	88,90 (3,50")	39,69 (1,56")	4	15,75 (0,62")	60,45 (2,38")	1,59 (0,06")	35,05 (1,38")	60,00 (2,36")	28,58 (1,13")
3/4" N.B.	150 LB	98,55 (3,88")	39,69 (1,56")	4	15,75 (0,62")	69,85 (2,75")	1,59 (0,06")	42,93 (1,69")	60,00 (2,36")	31,75 (1,25")
1" N.B.	150 LB	107,95 (4,25")	39,69 (1,56")	4	15,75 (0,62")	79,25 (3,12")	1,59 (0,06")	50,80 (2,00")	60,00 (2,36")	31,75 (1,25")
1 1/2" N.B.	150 LB	127,00 (5,00")	39,69 (1,56")	4	15,75 (0,62")	98,55 (3,88")	1,59 (0,06")	73,15 (2,88")	67,00 (2,64")	50,80 (2,00")
2" N.B.	150 LB	152,40 (6,00")	39,69 (1,56")	4	19,05 (0,75")	120,65 (4,75")	1,59 (0,06")	91,95 (3,62")	60,00 (2,36")	50,80 (2,00")
1/2" N.B.	300 LB	95,25 (3,75")	39,69 (1,56")	4	15,75 (0,62")	66,55 (2,62")	1,59 (0,06")	35,05 (1,38")	60,00 (2,36")	31,75 (1,25")
3/4" N.B.	300 LB	117,35 (4,62")	39,69 (1,56")	4	19,05 (0,75")	82,55 (3,25")	1,59 (0,06")	42,93 (1,69")	60,00 (2,36")	38,10 (1,50")
1" N.B.	300 LB	123,95 (4,88")	39,69 (1,56")	4	19,05 (0,75")	88,90 (3,50")	1,59 (0,06")	50,80 (2,00")	60,00 (2,36")	38,10 (1,50")
1 1/2" N.B.	300 LB	155,45 (6,12")	39,69 (1,56")	4	22,35 (0,88")	114,30 (4,50")	1,59 (0,06")	73,15 (2,88")	67,00 (2,64")	50,80 (2,00")
2" N.B.	300 LB	165,10 (6,50")	39,69 (1,56")	8	19,05 (0,75")	127,00 (5,00")	1,59 (0,06")	91,95 (3,62")	60,00 (2,36")	50,80 (2,00")
1/2" N.B.	600 LB	95,25 (3,75")	44,45 (1,75")	4	15,75 (0,62")	66,55 (2,62")	6,35 (0,25")	35,05 (1,38")	60,00 (2,36")	31,75 (1,25")
3/4" N.B.	600 LB	117,35 (4,62")	44,45 (1,75")	4	19,05 (0,75")	82,55 (3,25")	6,35 (0,25")	42,93 (1,69")	60,00 (2,36")	38,10 (1,50")
1" N.B.	600 LB	123,95 (4,88")	44,45 (1,75")	4	19,05 (0,75")	88,90 (3,50")	6,35 (0,25")	50,80 (2,00")	60,00 (2,36")	38,10 (1,50")
1 1/2" N.B.	600 LB	155,45 (6,12")	44,45 (1,75")	4	22,35 (0,88")	114,30 (4,50")	6,35 (0,25")	73,15 (2,88")	67,00 (2,64")	50,80 (2,00")
2" N.B.	600 LB	165,10 (6,50")	47,63 (1,88")	8	19,05 (0,75")	127,00 (5,00")	6,35 (0,25")	91,95 (3,62")	60,00 (2,36")	50,80 (2,00")
1/2" N.B.	900/1500 LB	120,65 (4,75")	44,45 (1,75")	4	22,35 (0,88")	82,55 (3,25")	6,35 (0,25")	35,05 (1,38")	60,00 (2,36")	31,75 (1,25")
3/4" N.B.	900/1500 LB	130,05 (5,12")	47,63 (1,88")	4	22,35 (0,88")	88,90 (3,50")	6,35 (0,25")	42,93 (1,69")	60,00 (2,36")	38,10 (1,50")
1" N.B.	900/1500 LB	149,35 (5,88")	50,80 (2,00")	4	25,40 (1,00")	101,60 (4,00")	6,35 (0,25")	50,80 (2,00")	67,00 (2,64")	38,10 (1,50")
1 1/2" N.B.	900/1500 LB	177,80 (7,00")	53,98 (2,13")	4	28,45 (1,12")	123,95 (4,88")	6,35 (0,25")	73,15 (2,88")	74,00 (2,91")	38,10 (1,50")
2" N.B.	900/1500 LB	215,90 (8,50")	60,33 (2,38")	8	25,40 (1,00")	165,10 (6,50")	6,35 (0,25")	91,95 (3,62")	67,00 (2,64")	50,80 (2,00")
1/2" N.B.	2500 LB	133,35 (5,25")	53,98 (2,13")	4	22,35 (0,88")	88,90 (3,50")	6,35 (0,25")	35,05 (1,38")	60,00 (2,36")	31,75 (1,25")
3/4" N.B.	2500 LB	139,70 (5,50")	53,98 (2,13")	4	22,35 (0,88")	95,25 (3,75")	6,35 (0,25")	42,93 (1,69")	60,00 (2,36")	38,10 (1,50")
1" N.B.	2500 LB	158,75 (6,25")	57,15 (2,25")	4	25,40 (1,00")	107,95 (4,25")	6,35 (0,25")	50,80 (2,00")	67,00 (2,64")	38,10 (1,50")
1 1/2" N.B.	2500 LB	203,20 (8,00")	66,68 (2,63")	4	31,75 (1,25")	146,05 (5,75")	6,35 (0,25")	73,15 (2,88")	80,00 (3,15")	50,80 (2,00")
2" N.B.	2500 LB	234,95 (9,25")	73,03 (2,88")	8	28,45 (1,12")	171,45 (6,75")	6,35 (0,25")	91,95 (3,62")	80,00 (3,15")	50,80 (2,00")

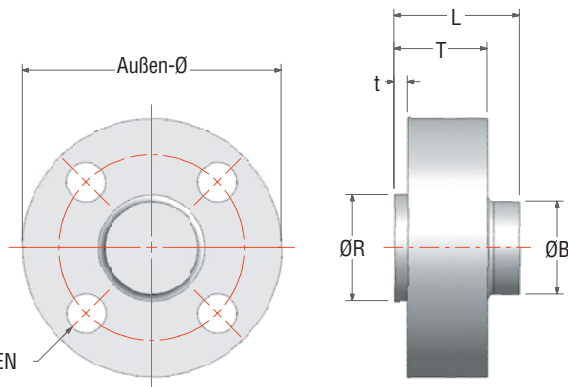

Höhe des installierten OS&Y-Ventils: 96,2 mm (3,79")  
 Höhe des installierten Nadelventils Baureihe H: 50,3 mm (2,00")  
 Höhe des zugriffsgeschützten Ventils Baureihe H: 48,8 mm (1,92")  
 Die Angaben oben beziehen sich auf ganz geöffnete Ventile  
 Hinweis: Das t-Maß gilt nur für „Raised-Face“ Dichtflächen.